

## Interior Visual Merchandising and its Role in Increasing Visual Attraction in Commercial Spaces

**Associ. Prof. Dr. Diao-Elden Mohamed Amin Tantawy**

Associate Professor of Interior Design, Interior and furniture design Department,

Faculty of Applied Arts/ Helwan University

[diaatantawy@hotmail.com](mailto:diaatantawy@hotmail.com)

**Assist. Lect. Amr Hesham Mohamed El Halaby**

Teaching Assistant of Interior Design Department - Faculty of Arts & Design – MSA

University

[halaby.jr@gmail.com](mailto:halaby.jr@gmail.com)

### Abstract:

Visual merchandising is the practice in the retail industry of developing floor plans and three-dimensional displays in order to maximize sales. Both goods and services can be displayed to highlight their features and benefits.<sup>1</sup> The purpose of such visual merchandising is to attract, engage, and motivate the customer towards making a purchase. Visual merchandising commonly occurs in retail spaces such as stores.<sup>2</sup> (Page 6)

Creating and maintaining a store's visual merchandising plan, however, is not a simple task. It is necessary to continually determine what the customer sees. This evaluation from the customer's perspective should start on the exterior and work completely through the interior of the store.

Eighty percent of our impressions are created by sight; that is why one picture is worth a thousand words. Each customer has a mental image of a store and its merchandise. A store should have an inviting appearance that makes the customer feel comfortable and yet eager to buy.

Some businesses maintain a minimum staff to reduce costs, which means it is even more important for the merchandise to sell itself. Greater effort must be spent on merchandise displays that make it easier for the customer to find and purchase the items they want or need.

The basic objective for visual merchandising is a desire to attract customers to a place of business in order to sell the merchandise. Visual merchandising is offered to the customer through exterior and interior presentation. Each should be coordinated with the other using the store's overall theme; however, it is not a simple task yet it is necessary to continually determine what the customer sees.

### Keywords:

Visual Merchandising – Commercial Design – Visual Attraction – Commercial Spaces.

### ملخص البحث :

التسويق البصري هو عملية يتم فيها تصميم للمساقط الأفقية والرسومات ثلاثية الأبعاد للفراغات التجارية بشكل يزيد المبيعات الأكبر قدر ممكن. فالبضائع والخدمات يمكن عرضهم بطريقة تبرز أهم ما يميزون به وفوائدهم للمستهلك. إن الهدف من التسويق البصري هو جذب وتحفيز المتسوقين تجاه عملية الشراء.

إن تصميم وإدارة خطة التسويق البصري لأحد المحلات التجارية ليس بالأمر السهل. فمن اللازم ان يتم باستمرار تحديد ما يراه المتسوقين داخل المكان, لذلك فإن دراسة الأمور من وجهة نظر المستهلك لابد ان تبدأ من التصميم الخارجي للمحلات التجارية, ثم التطرق خطوة تلو الأخرى للفراغات الداخلية.

إن ثمانون بالمائة من انطباعات المتسوقين تتكون من خلال حاسة البصر, لهذا السبب تساوي الصورة ألف كلمة. إن لكل متسوق أو مستهلك صورة معنوية لكل محل تجاري و منتجاته, و لذلك يتحتم علي كل فراغ تجاري أن يحظي بمظهر يرحب بالأشخاص المترددين عليه و أن يشعرهم بالراحة مع الإقدام علي الشراء.

تقوم بعض إدارات المحلات التجارية بتخفيض حجم العمالة لأقل قدر ممكن من أجل تقليل التكاليف, مما يعني أنه أصبح من الأهم و من الأدعي علي المنتجات أن تلعب دور أكبر في بيع نفسها بنفسها. فلا بد من بذل المزيد من الجهد في تصميم أماكن عرض المنتجات للتسهيل علي المتسوقين العثور علي المنتجات الراغبين فيها و شرائها.

إن الهدف الرئيسي للتصويق البصري هو جذب المزيد من المتسوقين الي مكان تجاري من أجل بيع المزيد من المنتجات. يقوم التسويق البصري بالتأثير علي المتسوقين من خلال العرض الخارجي و العرض الداخلي, و يجب التنسيق بين كلاهما و التأكد من إتباعهم للتوجه التصميمي العام للمكان, و هي ليست بالمهمة السهلة. فيجب أن يتم بشكل مستمر تحديد ما يراه المتسوقين مرتادي المكان.

### الكلمات المفتاحية:

التسويق البصري – التصميم التجاري – الجذب البصري – الفراغات التجارية

### Introduction:

When walking into a typical retail store, you'll likely notice tidy, curated products displays that visually highlight their items for sale. Those products aren't arranged that way by accident—the merchant is using visual merchandising best practices to help the products sell themselves. Essentially, a commercial space has to be the most productive and most efficient factor in selling more products, and visual merchandising employs the art of optimizing a retail store and product displays for maximum revenue. The discipline requires a sense of aesthetic, but it's also a science—visual merchandising is a tried-and-true strategy with results you can replicate in a retail space.

However, it's also important to recognize that the field of visual merchandising encompasses a lot of distinctive retail design topics. Best practices cover everything from creating effective window displays to the eye of prospective customers, to the signage you put up and your store layout, and much more.

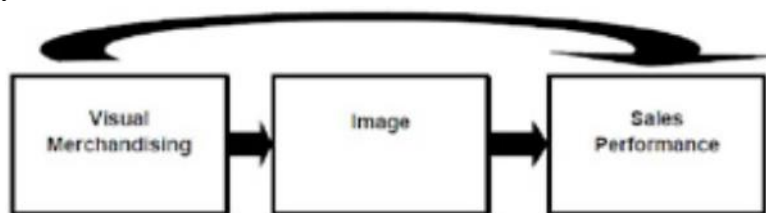

Figure 1 - Connection of Visual Merchandising, Image and Sales Performance.

### Research Problem:

Some products displayed in commercial spaces do not get enough visual attention from the customers.

**Research Goal:**

Finding new approaches regarding product display that are more visually attractive to customers.

**Research Methodology:**

Analytical, Descriptive Method.

**1. Exterior Presentation:**

The quality of a store facade is a major determinant for a customer, particularly a new customer, and should not be underestimated. The exterior appearance of one store, a block of businesses or a cluster, silently announces what customers can expect inside. Good exterior visual merchandising attracts attention, creates interest and invites the customer into the business. The exterior presentation can offer a conservative, progressive, lavish or discount image to the customer.

How a store visually welcomes customers has a lot to do with whether or not they enter the store. Although good prices and positive advertising through good reputation is important, it is hard to overcome the negative image of a poor store exterior.<sup>3(Page 4)</sup>

**1.1- Exterior Signs:**

A sign is a silent salesperson, and part of a shopper's first impression of a store. In less than 10 seconds the sign must attract attention, indicate what type of business this is, and what it has to sell. An effective sign will communicate what type of business is being conducted.

**1.1.1- Exterior Signs Roles & Requirements:**

Off-premise signs provide information and direction, especially for travelers and new residents. Signs can also help effectively communicate a poor location.

The lettering should be large enough to read from 200 feet, which is the distance required to stop a car traveling 40 miles per hour. Signs with 8-inch letters can be read from a distance up to 250 feet. A car traveling 55 miles per hour needs about 400 feet to stop. A sign requires 12-inch lettering to be read at that distance.

**1.1.2- Target Group:**

A sign's design conveys a great deal about the business inside. A stark design and limited materials may suggest discount prices and no frills. Elegant and expensive sign materials may suggest luxury goods and services. Signs may also be used to target a specific market segment such as youth, women, senior citizens, singles, etc.<sup>4 (Page 102)</sup>



Figure 2, 3 - An example for a high end sign for the Louis Vuitton brand vs. a regular one for the brand American Apparel.

### 1.2- Walks & Entries:

Approximately 75 percent of first time customers remember a store's entrance, which provides the first and last view of the store's interior. Picture walking up to an expanse of wall whose flat surface is pierced only by a plain glass door, as opposed to the protective feeling offered by walking under a porch or canopy.

A properly designed canopy or porch not only protects the customer in bad weather, but can add to the aesthetics of the building. When adding an entryway, be sure it is designed to blend or be consistent with the architecture of the building.

A cluttered entryway causes shoppers to indefinitely postpone entering a store, while an attractive, well designed entrance is more inviting to the customer. Entrances that allow shoppers to come into a store without being aware of their entering, is also becoming more popular. An example is a v-shaped window display that funnels window brings shopping traffic into the store. <sup>2</sup> (Page 6)



**Figure 4 - A store front with a canopy and a V-shaped entrance is considered to be welcoming to customers and of good aesthetic value.**

#### 1.2.1- Window Displays:

Special emphasis should be placed on a store's window displays because they are the information link to the potential customer. Window displays can be as important, if not more important, than advertising. As many as one in every four sales could be the result of a good window display.

The different elements of the window display directly convey a range of store-related as well as product category-related information.

Prior applications of cue utilization theory in the retail context suggest that consumers are likely to use these different elements, separately or in combination, as informational cues to make inferences about the product category and the store.

**These disparate types of meanings can be characterized along two continuous dimensions:**

### 1.2.1.1- The Primary Dimension:

The primary dimension reflects the substantive nature of the information. On one hand, the information can relate primarily to the retailer (e.g., retailer image). Alternately, consumers may use the window displays to obtain information about the product category (e.g., the latest trends/innovations).

### 1.2.1.2- The Secondary Dimension:

Captures the extent to which the information is directly evident from the window displays the information is directly evident from the window displays.

Along this dimension, information can either be observed or inferred. **Observed information** is obtained as it is from the window (e.g. promotional announcements) whereas **inferred information** (e.g. retailer image) refers to meanings generated on the bases of relevant informational cues (i.e. those with high predictive and confidence values. Next, we discuss these dimensions in detail.<sup>5 (page 278)</sup>

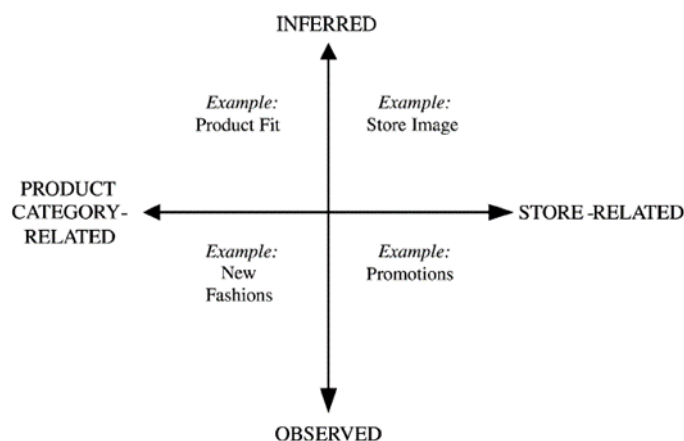

**Figure 5 - Dimensions of information acquired from window displays**

Window displays are more successful when a dominate theme is carried throughout the display, regardless of whether the featured products are fashion-oriented, institutional or promotional in nature.

### **Suggested window treatments that have proven to be successful include:**

- A single object against seamless paper.
- Merchandise displayed as it would be utilized in a realistic setting.
- A theatrical setting using fantasy and drama.
- Straight merchandise glamorized with props.
- Animation, such as in holiday windows that draws crowds of shoppers.
- The use of sculpture, paintings or art objects for a touch of class.
- Media tie-ins, with current area activities, films, stars or best-selling books.<sup>3 (Page 9)</sup>

## 1.2.2- Display Design & Fixtures:

### 1.2.2.1- Arena Principle for Display:

This display technique ensures that the entire product range is visible from the front mid-floor area close to the entrance right through to the back wall. The customer's field of vision is structured into different layers within the store – from the front / low area (mid-floor) to the

back / ceiling height area (back wall). Displays according to the arena principle can be used in shop-in-shops, large stores and in department stores.

If the arena principle is respected, the customer can spot the product ranges displayed at each level, right to the back of the store, from the main pathway. It gives the customer a good overview and draws him/her into the store.

#### 1.2.2.2- Layers within the store interior:

- Height of furniture directly next to the main pathway: 1.00 to 1.20 meters.
- Height of furniture in the center: 1.40 to 1.60 meters.
- Back wall elements: up to 2.60 meters in height.

Table displays and tiered tables are ideal for displaying folded and standing items at the front of the store. People generally find tables very inviting and they serve as a focal attraction for assorted product displays and decorative elements.

Stands and gondolas for hanging and, in some cases, folded merchandise are used in the center of the store. They can also be used selectively for promotional displays in addition to tables.

The back wall display is also visible above medium height stands and gondolas. The top zone is ideal for informative and decorative elements with a long range effect; it provides information on the type of merchandise on display, and entices customers to the rear of the store.<sup>6 (Page 58, 59)</sup>

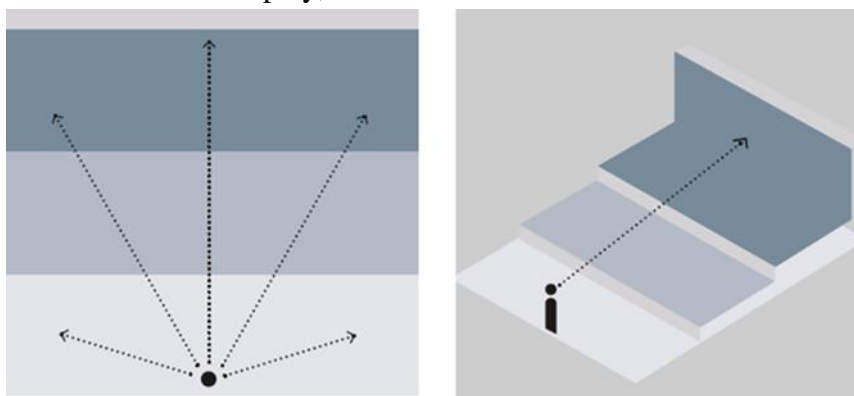

Figure 6, 7 – Top & isometric views for the Arena Principle showing the 3 different layers' heights and their relation to the customer inside the retail space.

#### 1.2.2.3- Types of Display Fixtures:

##### A- Wall Display:

Walls in commercial interiors are one of the most important display areas for the sale of merchandise. They play a decisive role in a store's/brand's image. Walls are generally used intensively for display purposes. Only in the premium segment is a small quantity of merchandise used to express exclusivity. Back walls should be divided into zones with individual themes. This creates an overview and facilitates customer navigation. Shelves and hanging rails at identical heights express serenity and orderliness, whilst offset heights create excitement.

##### The back wall can be divided into three functional zones:

##### I. The Top Zone:

It is used for information purposes. As this zone is visible above mid-floor elements, the consumer can see what can be found on the wall or in this department. The area should therefore be used for department/brand labeling, for image/brand photos or decorative purposes.

Attractive pictures and interesting decorative elements have a magnetic effect, drawing customers to the distant back wall. Good lighting in this wall section is, therefore, also particularly important.

## II. The Middle Zone:

It shows the merchandise theme. The merchandise display is already identifiable as the consumer approaches – this is decisive when it comes to inciting consumers to look and linger. The type, shape, color and material of the item must be visible. With textiles, front displays and folded items have a stronger and more appealing effect than side hanging displays; items are more easily identifiable and distinguishable in this manner. Identical items (in different sizes) should be hung one behind the other or placed on top of each other. It is also essential that items in the middle zone are hung at an accessible height to guarantee self-service.

## III. The Bottom Zone:

Large quantities of merchandise can be displayed in the bottom zone. This zone is often only visible directly in front of the wall when intensive use is made of the surface. Here the consumer can choose from different models, versions, sizes and prices. Side hanging displays are a space-saving option in the textile sector, enabling the display of a large quantity of merchandise and conveying the impression of an extensive choice. Varied merchandising techniques should however be used. Alternating between front and side hanging displays, between different items and colors demonstrates choice and variety, inciting curiosity and avoiding boredom.

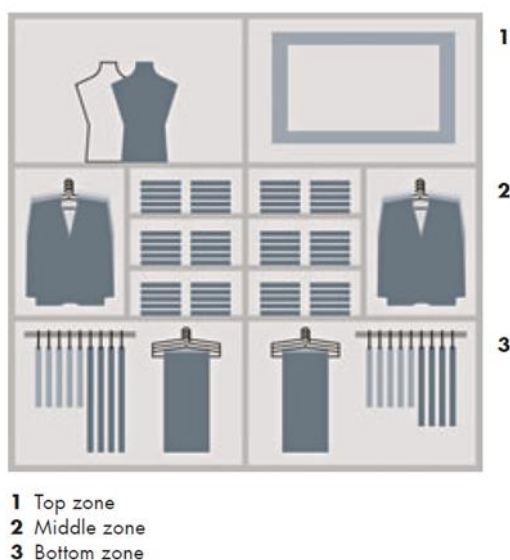

Figure 8 - Wall display zones chart showing different heights for different displayed items

## B- Mid-Floor Display:

The mid-floor area should be designed to match the style and shape of the wall units. The merchandise display in mid-floor should blend in perfectly with that of the wall display and the prevailing colors and theme. Various display units are available to enable effective use of the mid-floor sales area. Display tables, stand systems and gondolas are the traditional display units most commonly used in mid-floor.

### I. Display Tables:

Display tables always appear attractive and inviting – a presentation table is no different. Whether it features a luxury display or low-cost promotional items: a table rarely goes ignored. Assorted items can be arranged according to themes. Tables of different sizes or special tiered tables can create a rich variety of displays. Tiers are ideal for different sizes, colors or models. Busts and interesting flat displays increase the customer's attention. Presentations on table stands (e.g. small items such as accessories) highlight the merchandise and give it greater exposure.

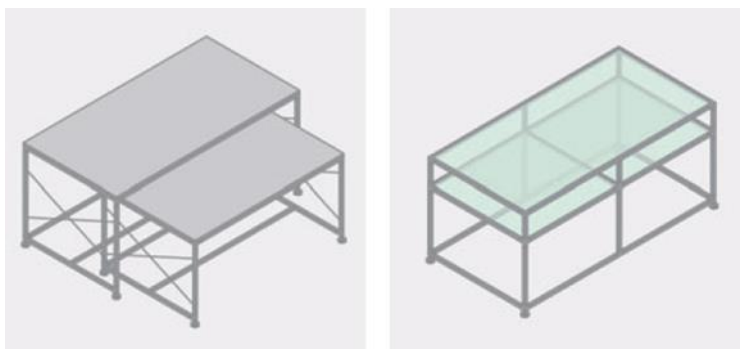

Figure 9, 10 - Tiered Table & Standard Display Table

### II. Display Stands:

Display stands come in various shapes and sizes. Round stands can carry large quantities of merchandise but only in side hanging displays, which reveal little of the style and shape of the garments. It is therefore mainly reserved for special sale offers or the latest seasonal goods. Other versions are single stands and bars (also double bars) – these are simple, straight stands which display garments in one or two directions.

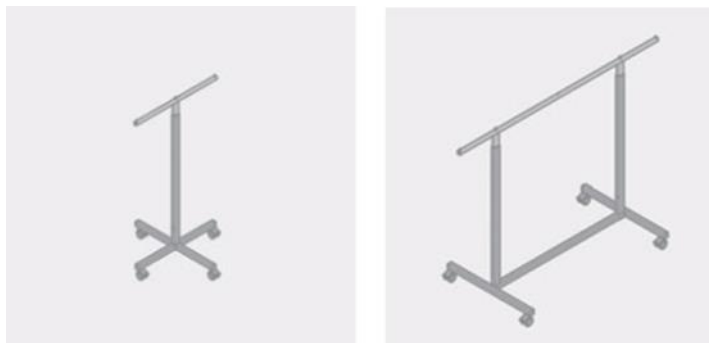

Figure 11, 12 – Single Stand & Bar Stand

Cross stands or waterfall stands are also available and present merchandise at a 90° angle in all four directions. Depending on the stand version, extension arms can be extended in fixed increments or on a continuous basis. Thanks to this range of heights, they can support a variety of different sized items in an exciting display. Whatever the type of stand, it can present style and color themes, combinations of product ranges or simply the same item in different sizes and colors. Hanging several identical items side by side in ascending size order guarantees orderly presentation. Sign holders can be placed in the center or on uprights for information or decoration.



### III. Gondolas:

Gondolas are larger mid-floor units which can carry merchandise on two or three sides. Wooden or glass partitions are used to create a better optical separation. Folded items usually feature alongside front or side-hanging merchandise, so that a complete theme can be displayed including accessories. Colors are aligned in horizontal or vertical blocks to create a harmonious overall visual effect.<sup>7</sup> (Page 8-13)

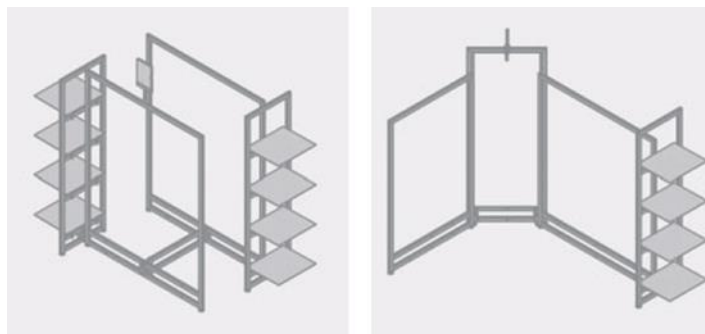

Figure 13, – Gondola units with shelving and hanging options

### Conclusion:

- 1- Visual merchandising is the practice in the retail industry of developing floor plans and three-dimensional displays in order to maximize sales.
- 2- How a store visually welcomes customers has a lot to do with whether or not they enter the store.
- 3- An exterior sign is a silent salesperson, and part of a shopper's first impression of a store. In less than 10 seconds the sign must attract attention, tell who the business is and what it has to sell.
- 4- Window displays are the information link to the potential customer. As many as one in every four sales could be the result of a good window display.

### References:

- 1- "Visual Merchandiser - The Job Guide", Department of Education, Employment and Workplace Relations, October 2011.
- 2- M M Pegler, "Visual Merchandising and Display", Fairchild Books, September 2018.
- 3- Holly Bastow-Shoop, Dale Zetocha, Gregory Passewitz, "Visual Merchandising - A guide for small retailers" North Central Regional Center for Rural Development, Iowa State University, May 1991.
- 4- Tony Morgan, "Visual Merchandising : Window and in-Store Displays for Retail", 2011.
- 5- Sankar Sen, Lauren G. Block, Sucharita Chandran, "Window Displays and Consumer Shopping Decisions", Journal of Retailing and Consumer Services 9, 2002.
- 6- "VM&RM Visual Merchandising and Retail Design Magazine", Volume 8, Issue 3, 15 December 2012 - 14 January 2011.
- 7- "Visual Merchandising – Guidelines for Practical Implementation", a study by the manufacturer "Visplay International GmbH".
- 8- Abdelrazik, A. (2019). A Strategy to Preserve and Promote the Egyptian Traditional Handicrafts. Magalet el omara w el fenon w el elom el ensanya, 4(13), 27-36.  
doi: 10.21608/mjaf.2018.20426